

# **BARONESS<sup>®</sup>**

## **Greens Mowers LM56/LM66/LM18G Series Installation Manual No.05 Assembly and Installation of De-Thatcher Ass'y**

---

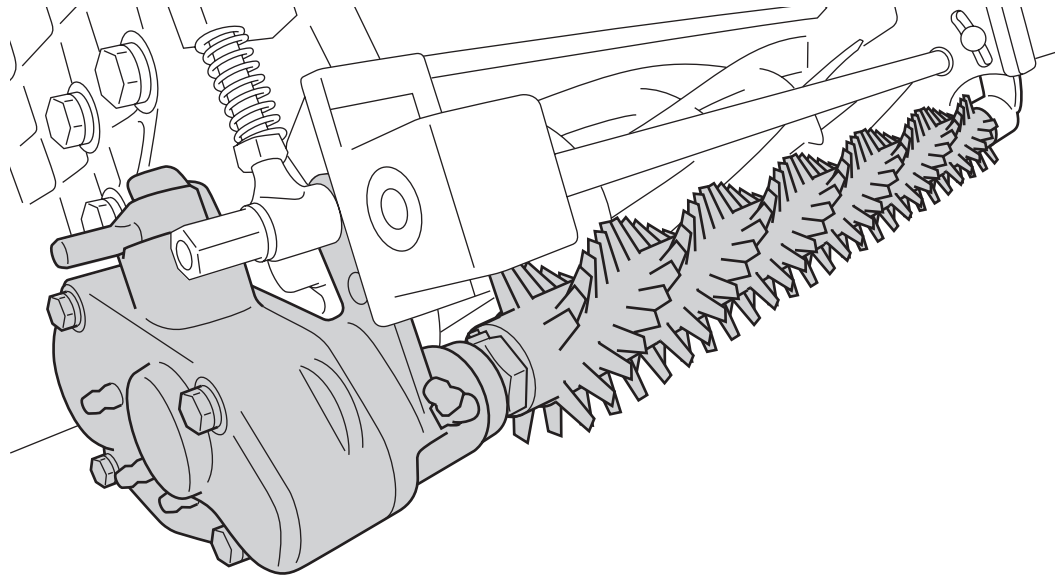

---

Kyoeisha USA Inc.  
[www.baroness.us](http://www.baroness.us)

Please use the following safety precautions when servicing a Baroness mower:

### **Wear protective clothing and gear.**

- Long pants, safety glasses, hard hat, gloves, and steel toe shoes or boots are recommended before doing any work on the greens mower. This will reduce your risk of injury.

### **Notes for installation.**

- Always refer to this installation manual or the owner's manual before beginning any work on the greens mower.
- Be sure to wear protective clothing and gear.
- "Left" and "right" directions in this manual are based on the viewpoint of the operator holding the handle of the mower and facing the mowing direction.
- Before doing any work on the mower, place it on a level surface and make sure all the switches are turned to the OFF position and that all the valves are closed.
- Engage parking brake and block tires while servicing the mower.
- Never attempt to install any parts or make any adjustments while the engine is running.
- Let the engine, muffler, and exhaust system cool before proceeding to service any parts which are in close proximity. These areas can be dangerously hot. Contact with these parts can cause bodily harm and or burns.
- Be mindful and take precaution around of the reel and blades as they contain sharp edges. These can inflict bodily harm and or injury.
- Always keep the safety symbols and instructions clean and attached to the mower. If they are lost or damaged, replace them immediately with new ones.
- Do not alter the machine. When replacing parts and grease, use only those specified by Kyoisha USA.
- The operation of a machine that has been modified or installed with parts other than those specified by Kyoisha USA could lead to mechanical malfunction resulting in damage to the mower and or injury to the operator.

Part	Part Num.	Part Name	Qty
A.	LM56G--8801Z0	De-thatching gear Ass'y	1
B.	K5051015280	1C5191P washer 1528	2
C.	LM56G--1212AR	Left vertical housing	1
D.	K0025080552	8 sq-root round-head bolt 55	2
E.	K0200080002	8S washer	2
F.	K0149083202	8-13 tall nut 20	2
G.	K0882045000	O-ring G45	1
H.	K6083000143	Right case locking bolt	1
I.	K1000000309	1.6 compression spring 13.720	1
J.	K5090000250	2C5191P washer 8.522	1

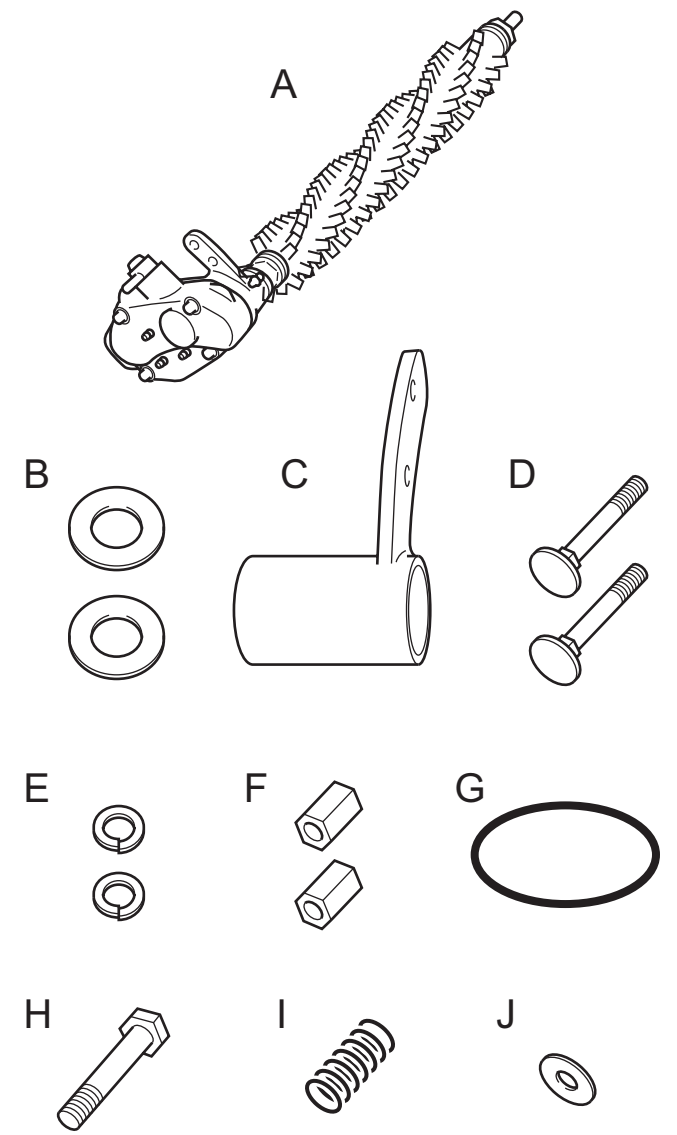

### Step 1.

Apply a generous amount of Excelite EP No. 2 grease to the O-ring, Part (G) before seating it into the recessed cut out in the attachment gear case housing.

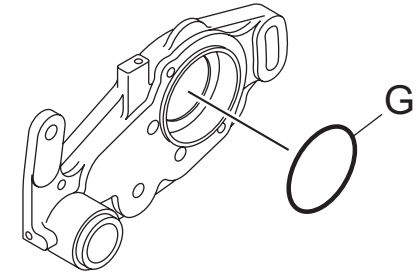

### Step 2.

Slide the opening of the attachment gear case housing of Part (A) over the exposed gears on the end of the reel shaft. Be sure not to dislodge Part (G) from its seated position.

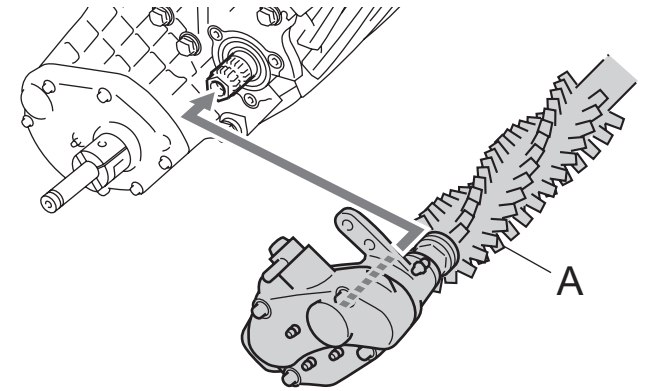

### Step 3.

Take Part (D) and insert it from the inside out, into the slotted hole in the right side frame's frontal portion. Ensure that the bolt goes through the upper hole in the attachment gear case housing of Part (A) continuing through the height adjustment bracket for the front attachment.

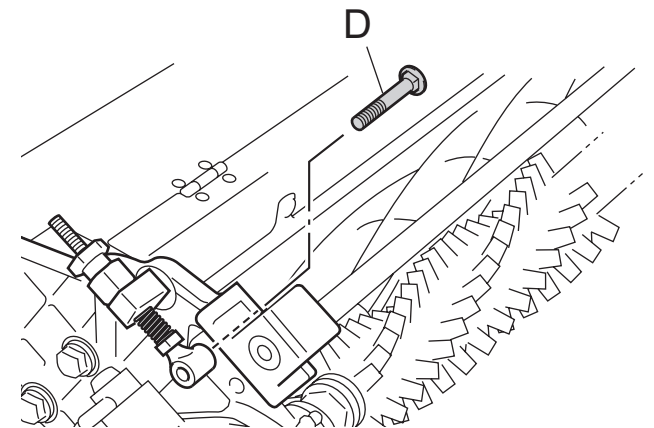

- \*\* Ensure that the raised tongue on the arm of Part (A) is properly seated into the groove on the left frame housing.
- \*\* The offset side of the round eye hole on the height adjustment should be against the frame.

Step 4.

Slide the 2 brass washers, Part (B) over the exposed end of the attachment shaft of Part (A). Then slide the Left vertical housing, Part (C) onto the shaft after the washers.

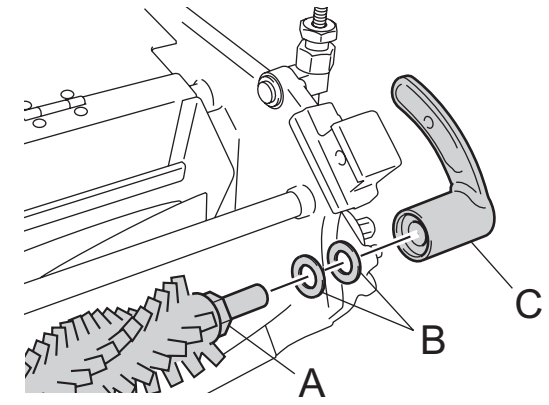

Step 5.

Insert Part (D) from the inside out, into the slotted hole in the left side frame's frontal portion, then through the upper hole on Part (C) and on through the height adjustment bracket.

- \*\* Ensure that the raised tongue on the arm of Part (C) is properly seated into the groove on the left frame housing.
- \*\* The offset side of the round eye hole on the height adjustment should be against the frame.

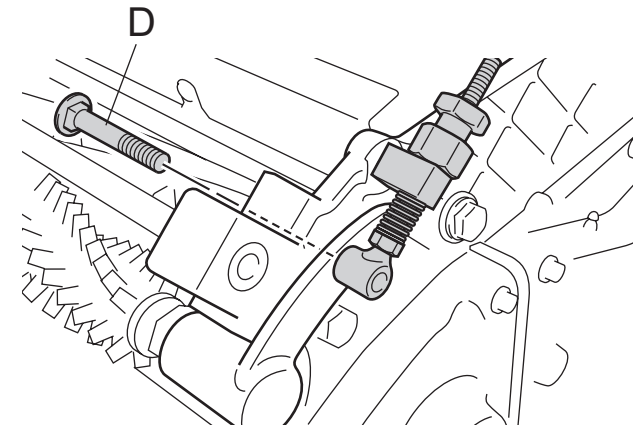

### Step 6.

Slide spring washer, Part (E) over the exposed threaded portion of Part (D), then thread tall nut, Part (F) onto the exposed thread of Part (D). Repeat for both right and left frame sides.

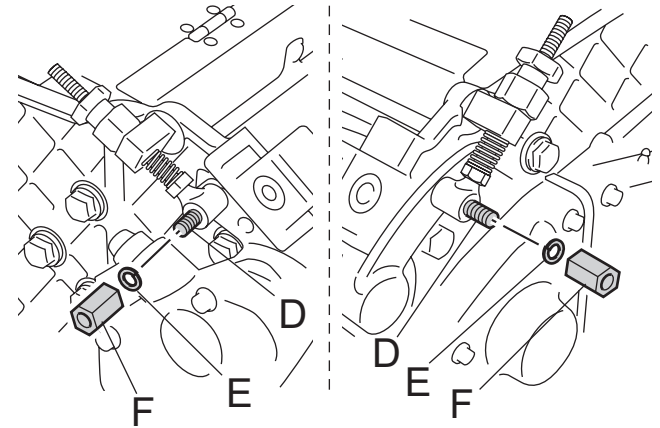

### Step 7.

Slide spring, Part (I) over the threaded end of right case locking bolt, Part (H), then slide washer, Part (J) over the threaded portion of Part (H). Insert Part (H) with Parts (I) and (J) fitted to it into the slotted hole in the rear of the attachment gear case housing Part (A), and thread into bolt hole in the right frame housing.

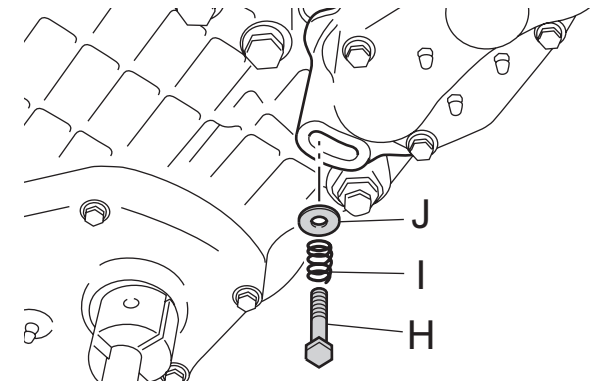

### Step 8.

Tighten Part (F) on both sides, ensuring not to excessively tighten. Over tightening can result in stripping of the nut or breaking of the bolt.

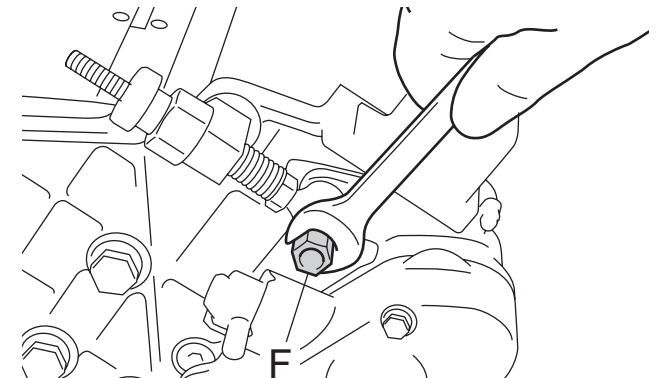

Step 9.

Tighten Part (H), but take extreme caution as to not over tighten this bolt. This bolt's function is to keep the attachment gear housing against the right frame housing while adjusting the height of operation. Excessive tightening will cause damage to the thread in the aluminum frame housing.

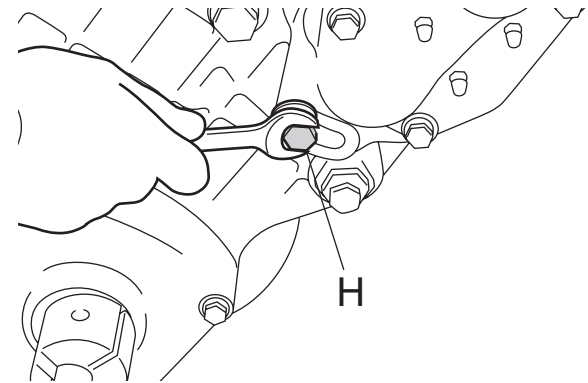

**BARONESS®**

Kyoeisha USA, Inc.  
1301 Rand Street, Suite D • Petaluma, CA 94954  
Phone: 707.283.0610 • Fax: 707.283.0613  
Web: [www.baroness.us](http://www.baroness.us)