

BARONESS®

Greens Mowers LM56/LM66/LM18G Series Installation Manual No.07 Assembly and Installation of Front Roller Ass'y

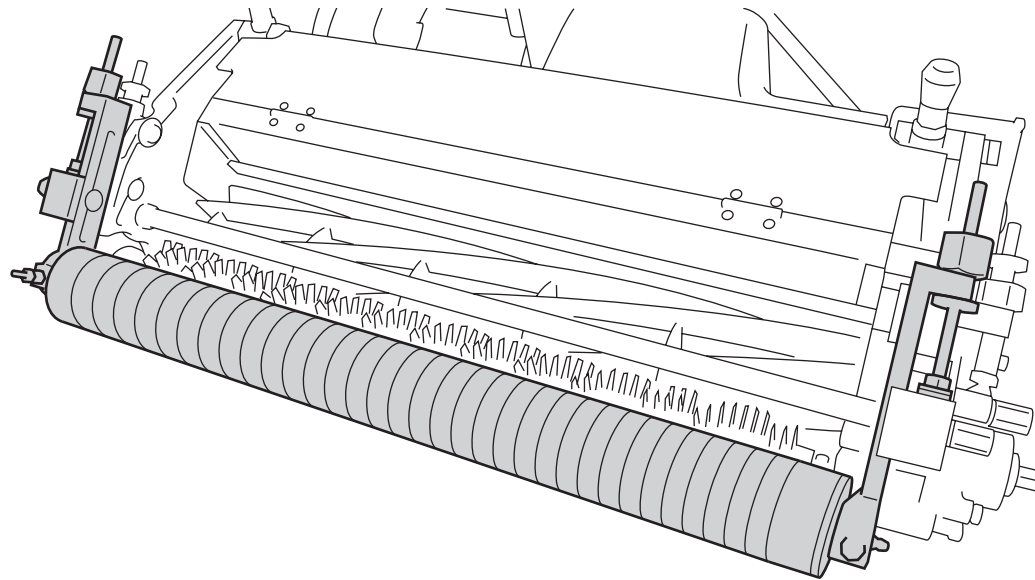

Kyoeisha USA Inc.
www.baroness.us

Please use the following safety precautions when servicing a Baroness mower:

Wear protective clothing and gear.

- Long pants, safety glasses, hard hat, gloves, and steel toe shoes or boots are recommended before doing any work on the greens mower. This will reduce your risk of injury.

Notes for installation.

- Always refer to this installation manual or the owner's manual before beginning any work on the greens mower.
- Be sure to wear protective clothing and gear.
- "Left" and "right" directions in this manual are based on the viewpoint of the operator holding the handle of the mower and facing the mowing direction.
- Before doing any work on the mower, place it on a level surface and make sure all the switches are turned to the OFF position and that all the valves are closed.
- Engage parking brake and block tires while servicing the mower.
- Never attempt to install any parts or make any adjustments while the engine is running.
- Let the engine, muffler, and exhaust system cool before proceeding to service any parts which are in close proximity. These areas can be dangerously hot. Contact with these parts can cause bodily harm and or burns.
- Be mindful and take precaution around of the reel and blades as they contain sharp edges. These can inflict bodily harm and or injury.
- Always keep the safety symbols and instructions clean and attached to the mower. If they are lost or damaged, replace them immediately with new ones.
- Do not alter the machine. When replacing parts and grease, use only those specified by Kyoisha USA.
- The operation of a machine that has been modified or installed with parts other than those specified by Kyoisha USA could lead to mechanical malfunction resulting in damage to the mower and or injury to the operator.

No.07 Parts List with IGCA(A)

Part	Part Num.	Part Name	Qty
A	LM56G--6812Z0	56G grooved roller Ass'y	1
B	K5051015470	1C5191P washer 1547	2
C	K6904000060	Left roller bracket	1
D	K0071000152	Left-hand thread roller bolt	1
E	K1440000010	Grease nipple	2
F	K0100060002	6 nut	2
G	K0000060252	6 bolt 25	2
H	LM56GA-2901A0	Roller adjuster screw 2008	2
I	K6084000162	Roller adjuster 2008	2
J	K0213080001	8 disc spring washer 1H	4
K	LM56GA-2903Z2	Right Stopper Bracket 2008	1
L	LM56GA-2902Z2	Left Stopper Bracket 2008	1
M	K6904000070	Right roller bracket	1
N	K6083000042	16 extension pin 19	1
O	K0025080452	8 sq.-root round head bolt 45	2
P	K5000080002	8 washer	4
Q	K0149083202	8-13 tall nut 20	2

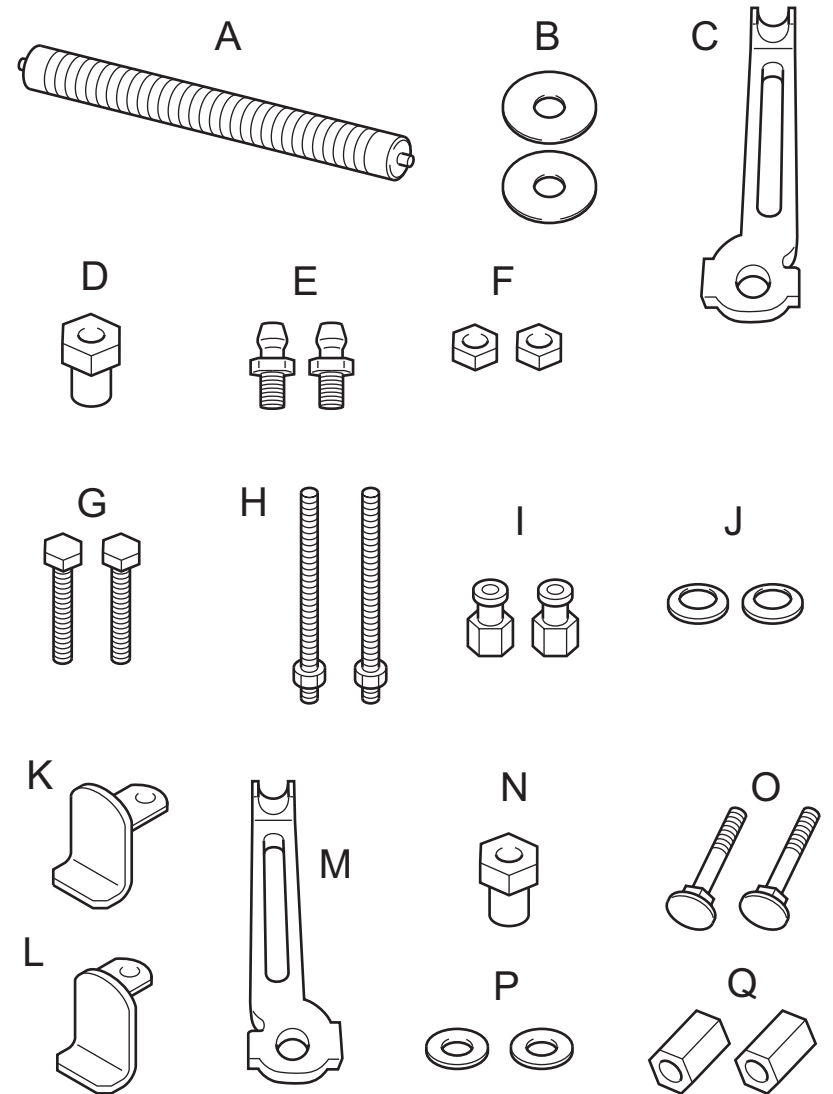

No.07 Parts List w/o IGCA(B)

Part	Part Num.	Part Name	Qty
A	LM56G--8201Z0	56G grooved roller Ass'y	1
B	K5051015470	1C5191P washer 1547	2
C	K6904000060	Left roller bracket	1
D	K0071000152	Left-hand thread roller bolt	1
E	K1440000010	Grease nipple	2
F	K0100060002	6 nut	2
G	K0000060252	6 bolt 25	2
H	LM56GA-2901Z0	Roller adjuster screw 2008	2
I	K6084000162	Roller adjuster 2008	2
J	K0213080001	8 disc spring washer 1H	4
M	K6904000070	Right roller bracket	1
N	K6083000042	16 extension pin 19	1
O	K0025080452	8 sq.-root round head bolt 45	2
P	K5000080002	8 washer	6
Q	K0149083202	8-13 tall nut 20	2

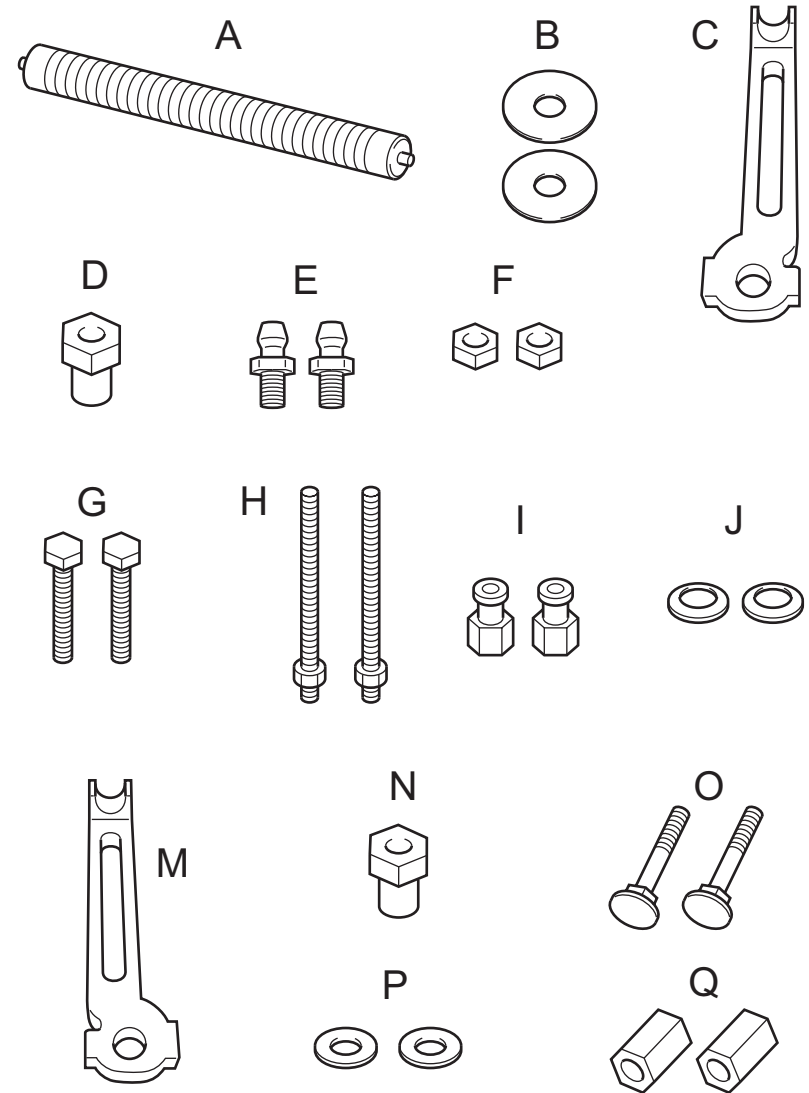

Preassembly:

Screw nut, Part (F) onto threaded leg of bolt, Part (G). When threading the nut, Part (F) onto Part (G), be sure to put round side of Part (F) on first. Repeat this so you have 2 sets of locking bolts. Now slightly screw threaded leg of Part (G) into front threaded hole on each roller bracket, Parts (C) and (M). Hand screw each locking bolt assembly so that the leg of Part (G) does not protrude into round cut out of Parts (C) and (M).

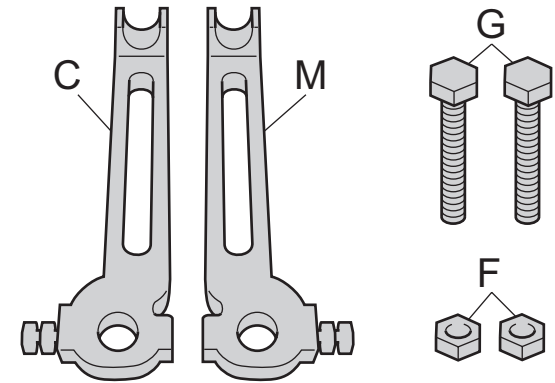

Assembly:

Step 1.

Hold front roller assembly, Part (A) with exposed shaft end facing upward, slide one washer, Part (B) onto protruding shaft of front roller, Part (A). Then slide left roller bracket, Part (C) onto shaft of Part (A).

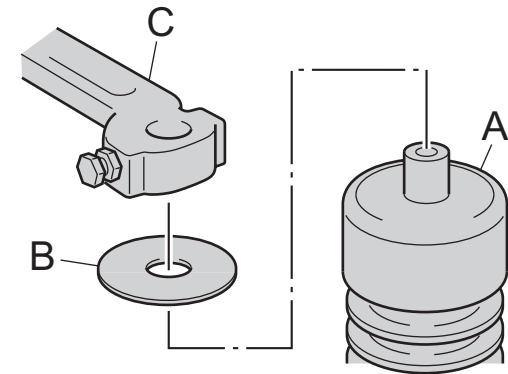

Step 2.

Make sure that the machined recess for the locking bolt on the shaft of Part (A) is facing forward, as in the direction of the threaded hole on the front flat side of Part (C).

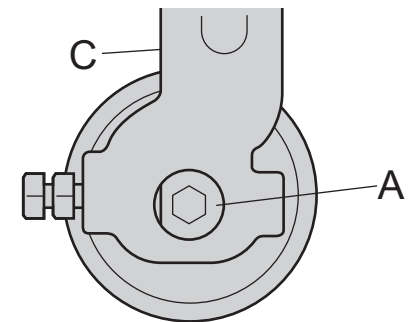

Step 3.

Now tighten down the locking bolt, Part (G) to contact the flat portion of the shaft. Secure locking bolt's position by tightening Part (F) to front side of Part (C). Do not over torque. This is currently a temporary step to hold the shaft into the desired position.

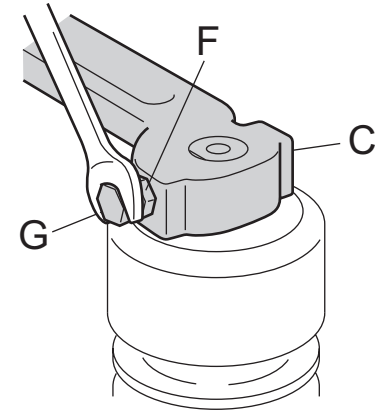

Step 4.

Screw Part (D) counter clockwise into left side of Part (A). Using 2 wrenches lock down the grease nipple, Part (E) into Part (D).

** For customers using an IGCA (Independent Grass Catching Arm) on their greens mower you will need different and extra parts. For customers without the IGCA, you will only need standard parts. Refer to applicable parts list.

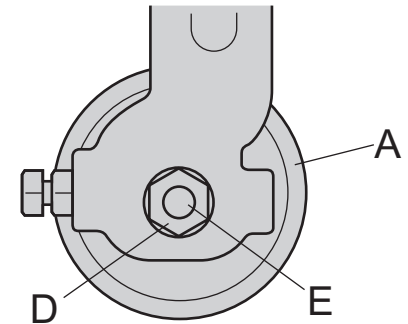

Step 5.

Take roller adjuster screw, Part (H) and tread roller adjuster, Part (I) on the longer threaded side till it is sitting about half way down the tread. The non nut side of Part (I) goes on first. Repeat to have 2 sets.

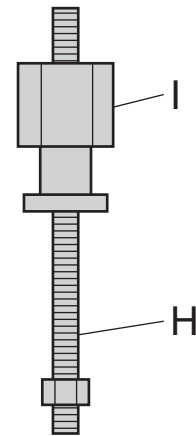

For customers with Greens Mower using IGCA

Step 6 (A).

Place one washer Part (P) into cut out slot on the front of the right side frame. Next place right independent arm bracket, Part (K) over Part (P). Then place Part (J) over Part (K), be sure that the convex side of Part (J) is facing upwards. Now screw short threaded side of Part (H) down through Parts (J), (K), (P), and into the frame. Check to see that Part (K) is centered then tighten and lock Part (H).

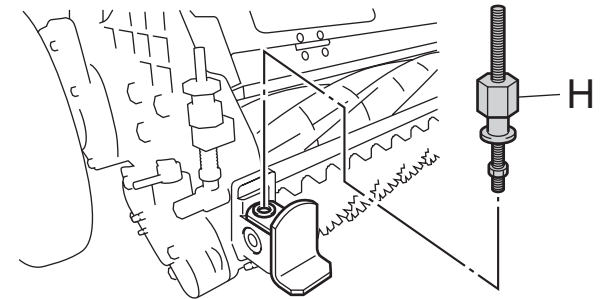
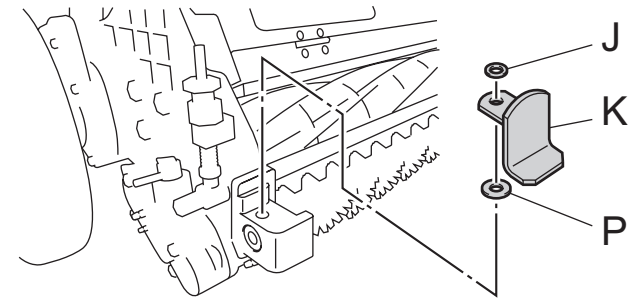

Step 7 (A).

Place one washer Part (P) into cut out slot on the front of the left side frame. Next place left independent arm bracket, Part (L) over Part (P). Then place Part (J) over Part (L), be sure that the convex side of Part (J) is facing upwards. Now screw short threaded side of Part (H) down through Parts (J), (L), (P), and into the frame. Check to see that Part (L) is centered then tighten and lock Part (H).

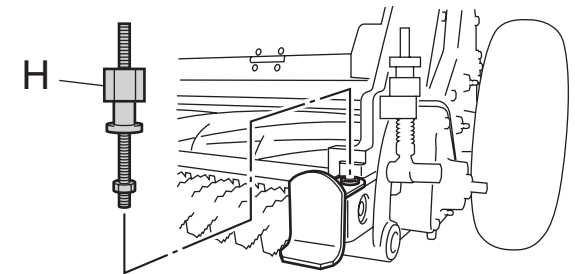
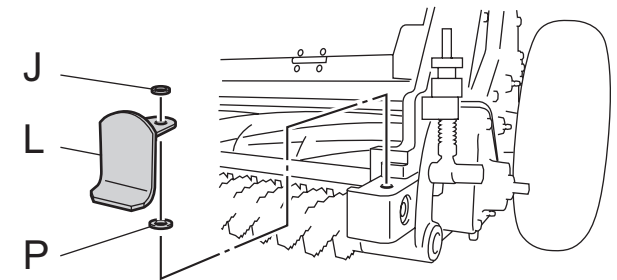

For customers with Greens Mowers not using IGCA

Step 6 (B).

Place two washers, Part (P) into cut out slot on the front of the right side frame. Next place Part (J) over Part (P). Be sure that the convex side of Part (J) is facing upwards. Now screw short threaded side of Part (H) down through Part (J) and into the frame. Tighten and lock Part (H).

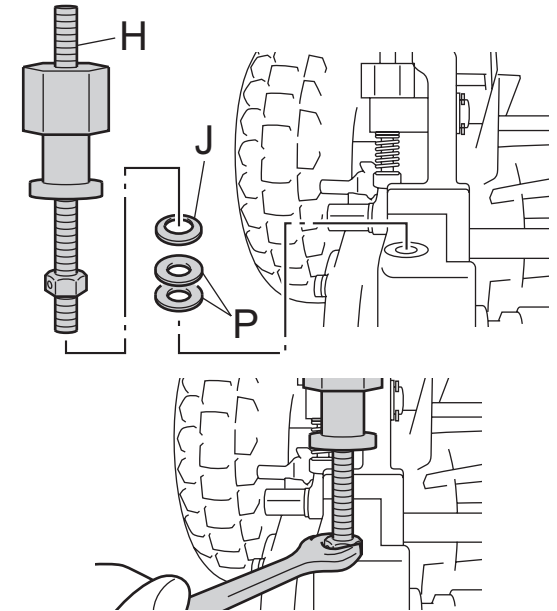

Step 7 (B).

Place two washers Part (P) into cut out slot on the front of the left side frame. Then place Part (J) over Part (P). Be sure that the convex side of Part (J) is facing upwards. Now screw short threaded side of Part (H) down through Part (J) and into the frame. Tighten and lock Part (H).

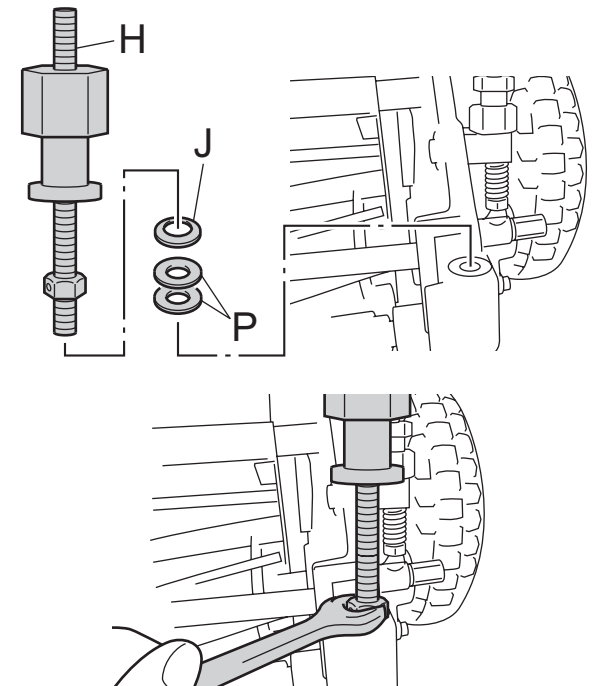

Step 8.

Lift Part (A), fit arm of left housing bracket, Part (C) into the adjustment recess on the front of the left frame. Take care not to damage the front attachment blades, by forcing the front roller into place when not correctly aligned. Slide the forked top of Part (C) onto round portion of Part (I).

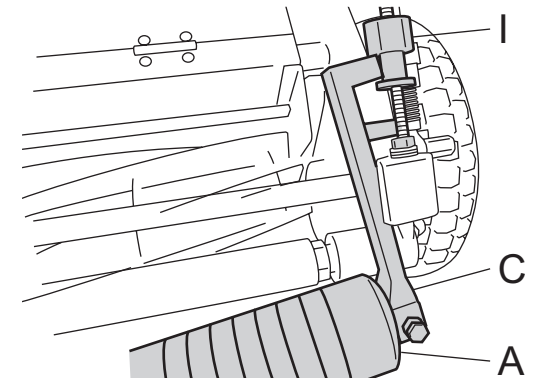

Step 9.

Once the left side is seated into the roller adjuster, Part (I) you can swap your hands to now support the right side of the roller. Next place remaining washer, Part (B) onto Part (A). You need to hold Part (B) against the right end of the roller, Part (A) while aligning the right roller bracket, Part (M) with the roller adjuster, Part (I). Ensuring that the right side roller bracket is properly seated into the recess and roller adjuster, Part (I). Support the roller, Part (A), washer, Part (B) and bracket, Part (M) with your right hand and insert extension bolt, Part (N) through Parts (M), (B), and into right side shaft of Part (A).

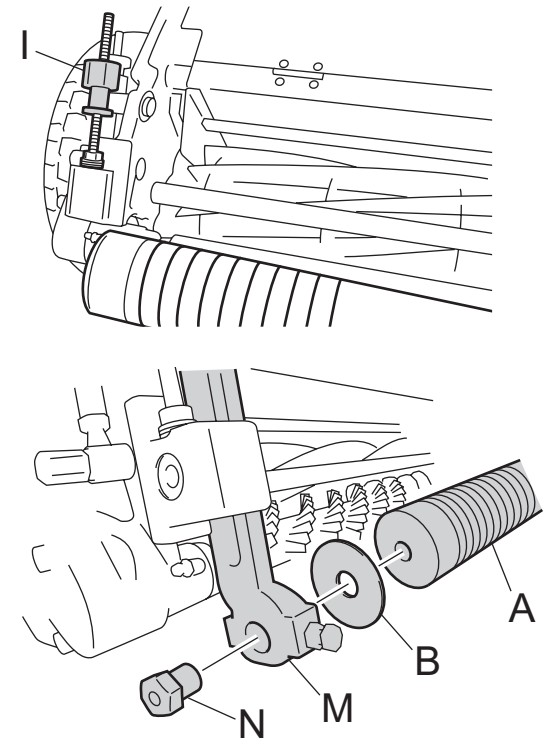

Step 10.

Insert sq.-root round head bolt, Part (O) through cut out slot of Part (M) then through right frame. Now on left side insert Part (O) through Part (C) and left frame from inside out direction. Make sure that the square base of Part (O) is seated in cut out slot on both sides in Parts (M), and (C). From the outside of the frame place Part (P) onto protruding leg of Part (O) followed by Part (J). Then screw Part (Q) onto threaded leg of Part (O). Do this for both sides. Part (J) should have convex side raised in the direction away from the frame with round side outwards towards Part (Q) on both sides.

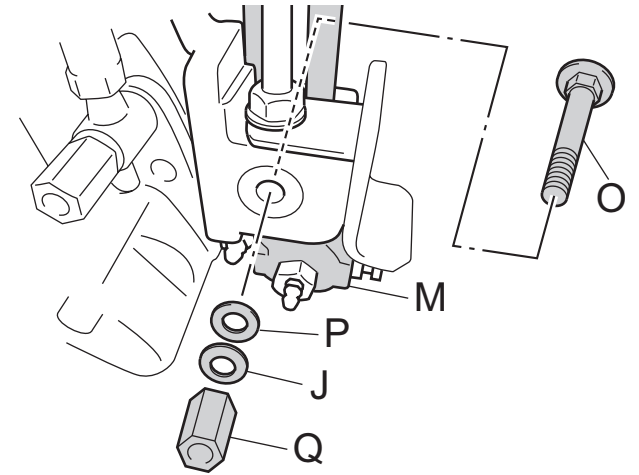

Step 11.

Tighten and lock Part (N) into right shaft of Part (A). Screw Part (E) into Part (N).

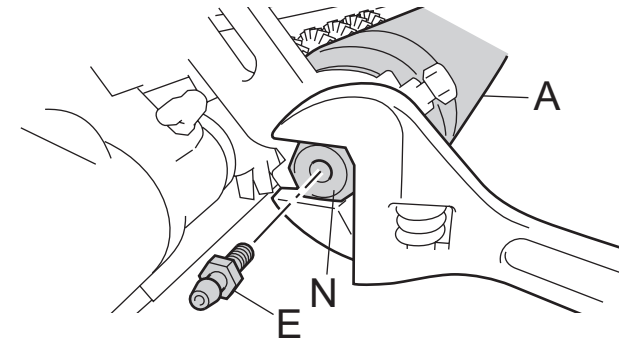

Step 12.

Tighten and lock Part (Q) on both sides.

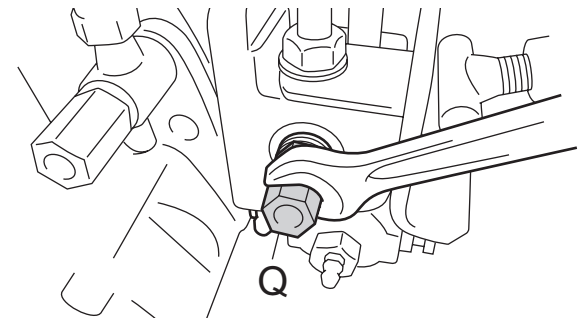

Step 13.

Unlock locking bolt on Part (C), by loosening Part (F) followed by Part (G). Just slightly loosen Part (G) off of shaft of Part (A). Do not want to back Part (G) too far off of shaft for shaft may spin excessively and you will lose positioning of the flat grooved surface.

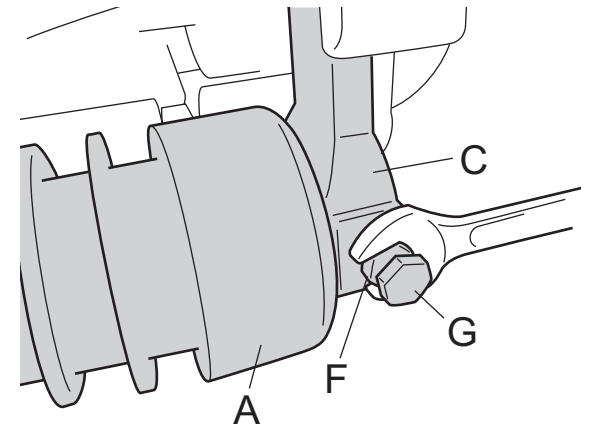

Step 14.

Spin roller to ensure it runs free and is not excessively tight on end washers, Part (B) on both sides.

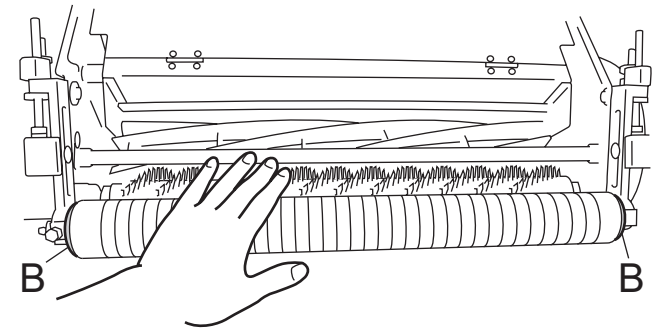

Step 15.

Screw and lock Part (G) onto shaft of Part (A) on both sides. Be careful when locking down Part (G). Do not over torque, over tightening may cause the bolt to fail or potentially damage the thread.

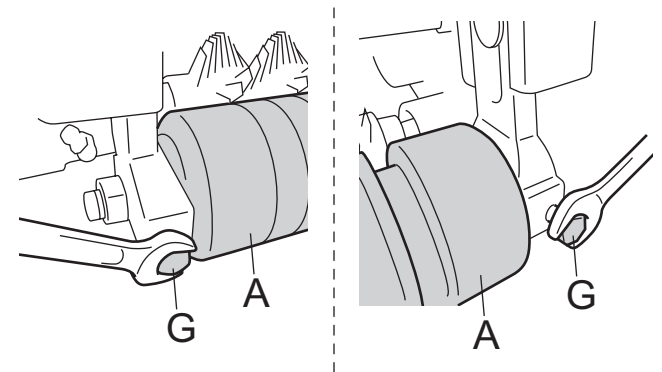

Step 16.

Tighten and lock Part (F) on both sides to secure and lock position on Part (G).

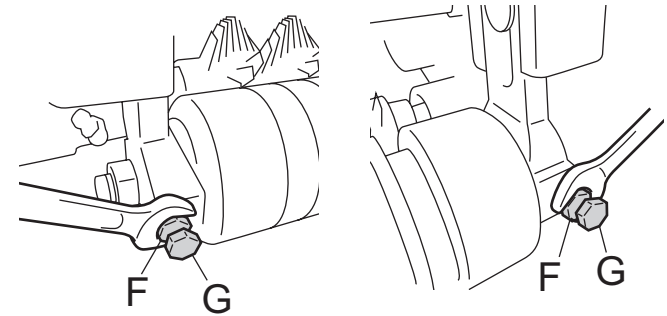
**Step 17.**

Add slight amount of grease to Part (E) on both sides. Pump grease while spinning Part (A) to feel for smooth rotation. Be cautious not to add too much grease. Over packing of grease will force the seals out of their seated position.

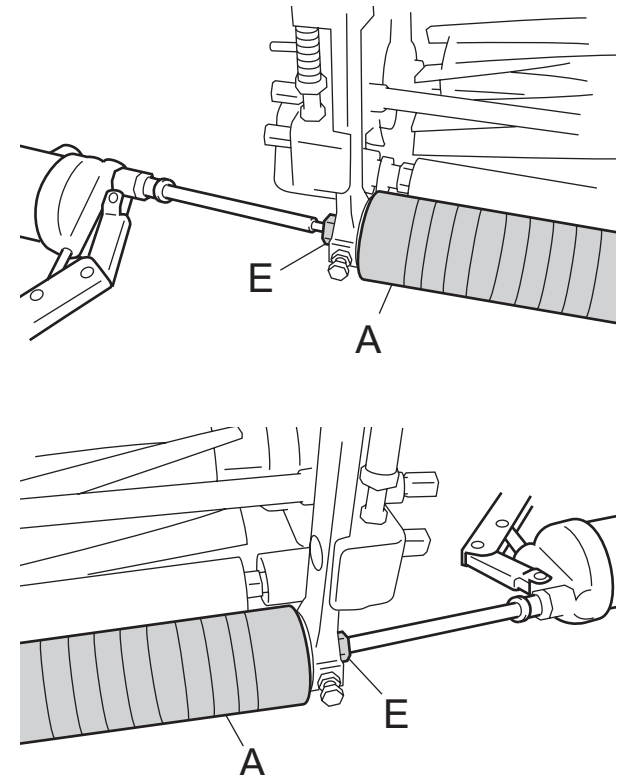

BARONESS[®]

Kyoeisha USA, Inc.
1301 Rand Street, Suite D • Petaluma, CA 94954
Phone: 707.283.0610 • Fax: 707.283.0613
Web: www.baroness.us